

# Non-Contact Temperature Monitoring System to Optimize Health Working Environment Based on IoT

Luki Ardiantoro\*, Moh. Muslimin, Yesy D. Rosita

Department of Informatics, Universitas Islam Majapahit, Jl. Raya Jabon km 7, Mojokerto 61363, Indonesia

\*Corresponding author: ipan.ardianto@gmail.com

Article history :  
Received: 30 DES 2022  
Accepted: 22 FEB 2023  
Available online: 11 JUL 2023

Research article

**Abstract:** During the ongoing COVID-19 pandemic, monitoring body temperature is a crucial concern for the community, and it serves as an essential step in understanding the health condition of an individual's body. The workers in environments that involve physical contact and are prone to dirt are at a higher risk of contracting COVID-19. In this study, we created a body temperature detector to optimize the working environment in the waste processing area of Mojokerto Regency. Several modules and devices have been utilized, including the Arduino Uno R3 module, an ultrasonic sensor for object detection and temperature sensing, MLX90614 for detecting body temperature, and a buzzer system. The SDLC (Build & Fix design) method was employed to simulate the actual conditions at the Randegan Landfill in Mojokerto. Consequently, the designed IoT device can automatically send information and provide follow-up through a network of various functions. It can be concluded that the developed body temperature detection device has the potential to minimize the risk of contracting COVID-19 and enhance healthier and more productive working conditions.

**Keywords:** BODY TEMPERATURE; IOT; WORKING ENVIRONMENT; GARBAGE; ARDUINO

Journal of Intelligent Computing and Health Informatics (JICHI) is licensed under a Creative Commons Attribution-Share Alike 4.0 International License



## 1. Introduction

Garbage is a source of environmental pollution if it is not managed properly, and it can cause environmental problems such as being a source of various kinds of diseases, a dirty environment, a bad smell, and one of the causes of flooding in big cities due to waste entering waterways. The same situation occurred in Mojokerto, a city located 50 km west of Surabaya, East Java, Indonesia.

Traditional markets act as waste generators in Mojokerto. Based on data from the Dinas Lingkungan Hidup (DLH) in Mojokerto City's environmental services office, the composition of the waste varies between 70 and 80%, with water content varying between 50 and 70%. From these data, it is clear that the organic component of the market waste has a high water content. Therefore, even if the waste is not handled for one day, it causes the waste to smell badly, resulting in a market environment that is dirty, smelly, and unhygienic. The amount of waste that goes to the Randegan TPA (tempat pembuangan akhir or landfill), Mojokerto City, continues to grow every day. While the process effort for volume reduction was relatively insignificant. If things like this continue to happen, then with the amount of incoming waste reaching a volume of 9 tons per day, it will be very troublesome. The Mojokerto district government also has constraints in the form of limited available land.

In the current Smart City 4.0 era, Mojokerto seeks to integrate technology into city governance by utilizing Internet of Things (IoT) technology. IoT is a network of interconnected electronic devices that aims to extend the benefits of Internet connectivity in real time to send data.



Fig 1. Randegan landfill treatment

Processing waste requires a strict schedule for both the waste collection process and the delivery of waste to the

landfill. Owing to the high demand for waste transportation and high mobility of the waste collection fleet, a good monitoring and management schedule is required. Delays in waste collection can cause temporary disposal sites (TPS) and waste depots to become full and unable to accommodate the waste that continues to arrive. Therefore, the process of transporting and sorting waste is very important for maintaining its sustainability. In addition, physical contact will often occur, which will increase the risk of getting COVID-19. During the Covid-19 pandemic, a system that can proactively detect the body condition of all workers at landfills is needed.

Human temperature influences the state of the body; therefore, monitoring employee body temperature is urgent and important for companies.

## 2. Research Methodology

We used rapid prototyping and a build and fix system development live cycle (SDLC) approach to deploy the body temperature detection system. This method was chosen because it is practical, easy to implement and evaluate, and has commonly used stages, such as planning, analysis, design, implementation, testing, and maintenance. The steps taken were as follows: (a) focus group discussion, (b) field survey, (c) iot planning, and (d) simulation and testing.

To collect the data, we used a field survey technique involving a team from the DLH Mojokerto City Government. The data from DKP Mojokerto City show that the composition of waste and moisture content varies greatly between 70-80% and 50-70%.

According to the WHO, the human body temperature is said to be normal at 37.2 °C– 37.5 °C. Hypothermic (< 35 °C), hypertemia (> 37.5 – 38.3°C), hyperpyrexia (> 40 °C– 41.5 °C).

Body temperature measurement is an initial measure used to detect the early symptoms of COVID-19. In this study, we conducted simulations to model an actual situation. Modules and various devices are required to build a system that is automatically integrated. Some of them are ultrasonic sensors to detect objects, and MLX90614 sensors are used to measure body temperature. The body temperature data were then processed by the Arduino Uno R3, and the output results were displayed on the 16 × 2 LCD along with the buzzer output indicator.

## 3. Result & Discussion

### 3.1 An excellent workplace

One of the indicators of a good work environment criteria can be seen in its management, which can influence and create safe, healthy, and profitable working conditions. Apart from management, good relationships between coworkers are also an example of a good working environment because communication between workers is considered to create comfortable and pleasant conditions within the company. A healthy work environment can improve employee performance. For example, providing a room that is clean, not dusty, neat, and so on can reduce the risk of contracting COVID-19.

### 3.2 Main activities

Generally, there are three stages of waste management activities in urban areas: collection, transportation, and final treatment (Aboejoewono, 1985). Waste collection refers to the management of waste from its place of origin to temporary disposal sites before moving to the next stage. Transportation is the tool and vehicle used to transport waste to temporary disposal sites (TPS/Depo). The final process is a filter process to separate dry and wet waste.

### 3.3 System design

A non-contact temperature monitoring system will be placed at the entrance in each workspace at TPA Randegan, Sekar Putih (Mojokerto). Any worker who is detected to have an abnormal body temperature will be detected, and the buzzer alarm will be activated. Then, workers who are unwell will be asked to go home, and then carry out further medical action or self-isolation. The system design and IoT architecture are illustrated in Fig. 2 and 3.

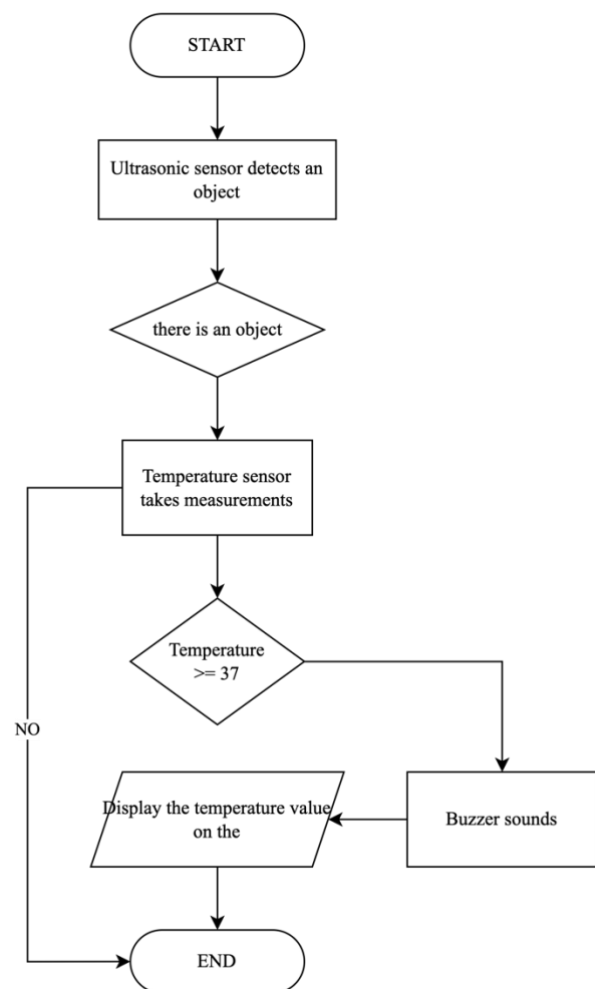

Fig 2. Flow chart of system design

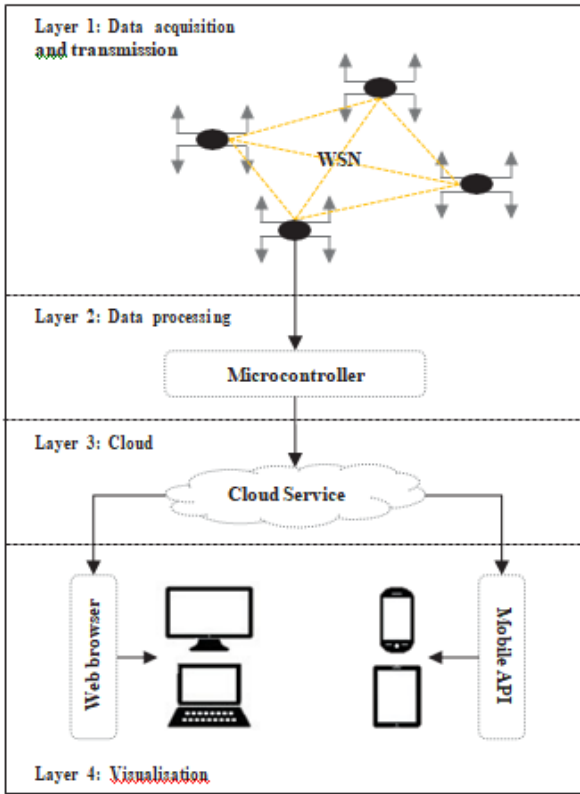

Fig 3. IoT system architecture

**3.4 System Hardware**

*a. Infrared temperature sensor*

The ML X90614 sensor is an infrared thermometer that is used to measure the temperature without contact with objects. This sensor consists of a detector chip that is sensitive to infrared based on temperature and signal conditioning, which is integrated with ASSP with TO-39. This sensor is supported by a low-noise amplifier, a 17 bit ADC, a DSP unit, and a thermometer that has high accuracy and resolution. The thermometer was calibrated with digital outputs from the PWM and SMBus. As a 10-bit PWM standard, temperature changes are displayed, which are measured continuously with a temperature range on the sensor minus 40 to 120 °C and an object temperature range from -70 to 380 °C with an output resolution of 0.14 degrees Celsius.



Fig 4. The infrared temperature sensor X90614

*b. Arduino Uno R3*

Arduino is an open-source single-board controller, designed to facilitate the use of digital electronics in various fields. Arduino is an electronic kit or open source electronic circuit board whose main component is a microcontroller chip with the AVR type from the Atmel company. Arduino Uno has 14 digital input / output pins (or commonly written I/O, where 14 pins of which can be used as PWM outputs between other pins 0 to 13), 6 analog input pins, using a 16 MHz crystal including pins A0 to A5, USB connection, power jack, ICSP header and reset button.



Fig 5. Arduino uno R3 controller

*c. Ultrasonic sensor*

An ultrasonic sensor converts physical quantities (sound) into electrical quantities and vice versa. This sensor works based on the principle of reflection of a sound wave so that it can be used to interpret the existence (distance) of an object with a certain frequency.



Fig 6. Ultrasonic sensor

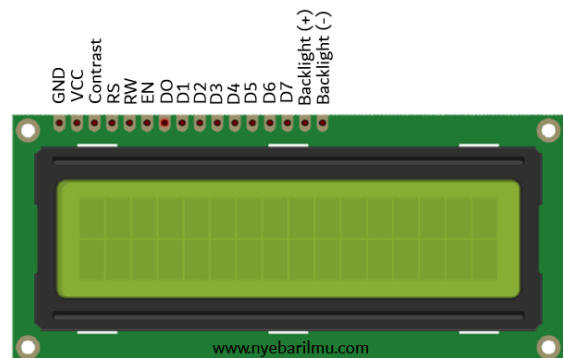

Fig 7. LCD module (16 x 2)

d. LCD (16 x 2)

LCD 16 x 2 (Liquid Crystal Display) is a data display module that uses liquid crystals as a material for displaying data in the form of text or images. Applications in everyday life that are easy to find include calculators, gamebots, televisions, or even computer screens. It has 16 characters and two rows of information display.

e. Buzzer

A buzzer is an electronic component that converts current vibrations into sound vibrations. The buzzer had an electromagnetic coil attached to the diaphragm.



Fig 8. Buzzer

3.5 System software

The integrated development environment (IDE) is intended for making commands or source code, checking errors, compiling, uploading programs, and testing Arduino work through a serial monitor.

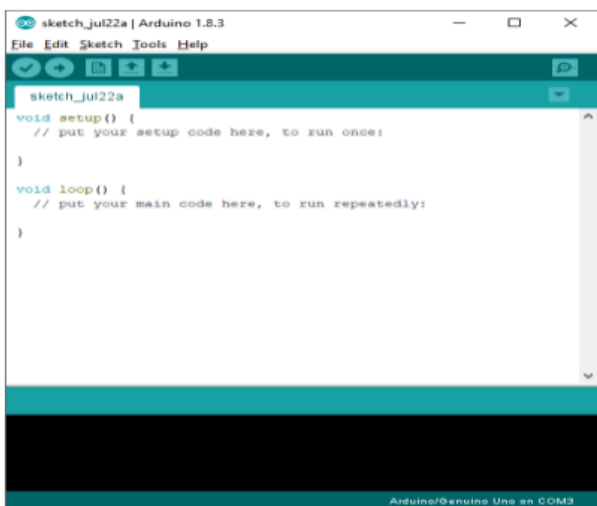

Fig 9. Ingrated development environment for arduino

The results of this design are simulated using tinkercad software before being designed in hardware. Tinkercad can provide input functions and the response of the microcontroller program in the output form in response to the input signal. The output of the Arduino Uno uses a quad-coupler model to drive the alarm buzzer switch.

4. Implementation

In this implementation section, controller programming is carried out in the software, with the listing program shown in Fig. 9 and 10.

(Luki Ardiantoro)

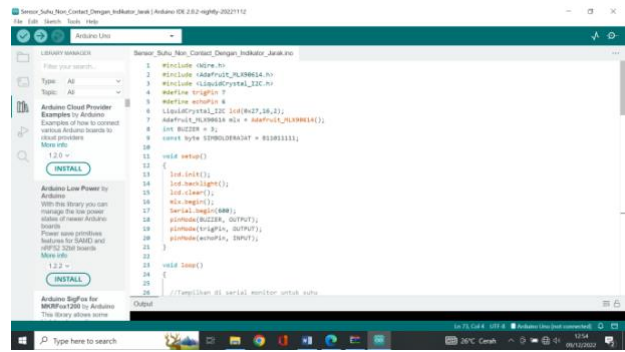

Fig 10. IDE for NCTM system (1)

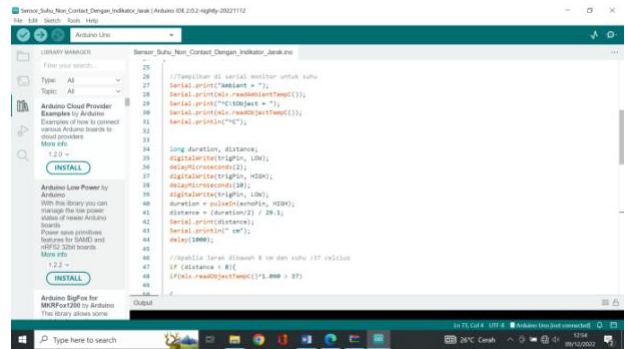

Fig 11. IDE for NCTM system (2)

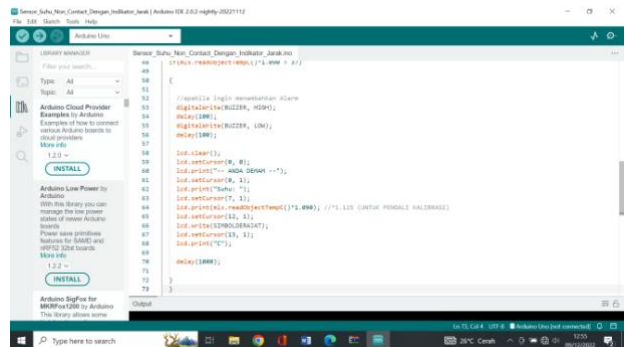

Fig 12. IDE for NCTM system (3)

In addition, the installation and connection of controller devices with various input and output media of the designed system are carried out, as described in Tables 1 through 4. Table 1 shows the connection model for the ultrasonic device connection. This equipment is used to detect objects and humans in the input stage.

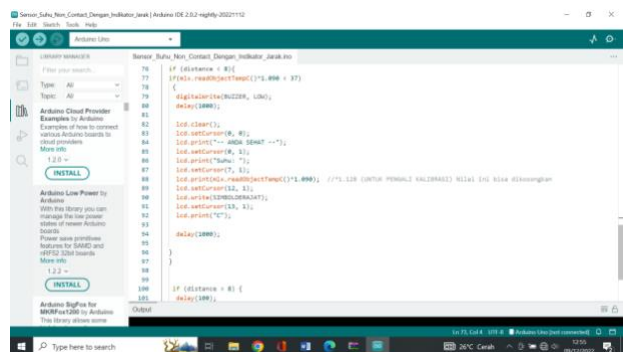

Fig 13. IDE for NCTM system (4)

The design draft for this system includes tools and Materials Hardware:

- a. MLX90614 Temperature Sensor
- b. Arduino Uno R3
- c. Ultrasonic Sensors
- d. LCDs 16x2
- e. Breadboards
- f. Jumper Cable

Software: Arduino IDE as an editor application for Arduino programming.

2. Sensor Design

Table 1. Ultrasonic device connection

PIN ARDUINO UNO	TEMPERATURE DEVICE
Pin 7	Trig SCL/RX
Pin 6	Echo TX/SDA
Power 3.3V	VCC
Ground	GND

Table 2 shows the connection model for the temperature of the device connection as an input mechanism to detect the human/worker body temperature.

Table 2. Temperature device connection

PIN ARDUINO UNO	TEMPERATURE DEVICE
Power 3.3V	VIN
SCL	SCL
SDA	SDA
Ground	GND

Table 3 shows the connection model for the buzzer as an output warning mechanism for abnormal body temperature. The buzzer will be activated if a worker temperature anomaly is detected by infrared input sensors.

Table 3. Buzzer

PIN ARDUINO UNO	BUZZER
Ground	GND
Pin 3	Positif (+)

Table 4 shows the connection model for the temperature device as an output mechanism for an abnormal body temperature indication display.

Table 4. Temperature device

PIN ARDUINO UNO	TEMPERATURE DEVICE
Power 5V	VCC
A5	SCL
A4	SDA
Ground	GND

Fig. 14 depicts a series of overall system functions, including the input sensors and output mechanism.

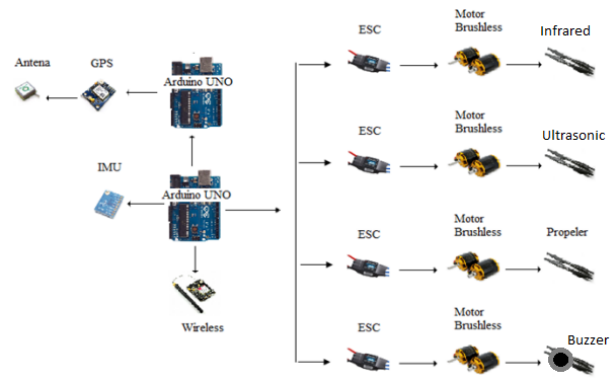

Fig 14. Non contact temperatur system

Level of accuracy of measuring body temperature at a distance of 5 cm. There are differences in measurements based on distance; the farther the distance, the smaller the measurement results.

5. Conclusion

The IoT can be leveraged to enhance waste management performance, starting with transportation, stockpiling, storage, and efficient waste decomposition. Community awareness and local government initiatives are crucial for planning, implementing, controlling, and supervising the use of eco-friendly waste processing technologies.

Acknowledgements

We express our sincere appreciation to Dr. Ikfina, Mr. Bagus, the head of DLH Mojokerto, and the DLH Mojokerto team for generously sharing their invaluable insights and experiences as field operators at Randegan landfill. Furthermore, we extend our gratitude to the Faculty of Engineering at Universitas Islam Majapahit, Mojokerto, for their unwavering support and encouragement throughout the entire research process.

Conflict of interest

The authors declare that they have no known competing financial interests or personal relationships that could have influenced the work reported in this paper.

References

Aboejowono, A. (1985). *Pengelolaan Sampah Menuju ke Sanitasi Lingkungan dan Permasalahannya*; Wilayah DKI Jakarta Sebagai Suatu Kasus. Jakarta. Dinas Kebersihan Kota DKI Jakarta. (1985). *Permasalahan dan Pengelolaan Sampah Kota Jakarta*. Jakarta. Murtadho, D. dan Sa'id, E. G. (1988). *Penanganan Pemanfaatan Limbah Padat*. Sarana Perkasan. Jakarta. Tiwow, Clara., dkk, (2003). *Makalah Pengantar Falsafah Sains (PPS702)*, Program Pasca Sarjana IPB, Bogor Posted: 1 May 2003. Danang Setiaji, (2018), *Apa Itu Smart City dan Tantangan Penerapannya di Indonesia*. <https://id.techinasia.com/apaitu-smart-city-dan-penerapan-di-indonesia> Naashir, (2014). *Smart City*, <https://naashir.wordpress.com/2014/11/07/smart-city/> NN., (2017), *Smart City 4.0*, <https://berkeleysmartcities.com/> Shinta Esabella, (2016), *Menuju Konsep Smart City*, Universitas Teknologi Sumbawa, NTB.

- Benazzouz. Y, Munilla. C, Gunalp. O, Gallissot. M, Gurgun . L, (2014). Sharing User IoT Devices in the Cloud, in IEEE World Forum on Internet of Things (WF-IoT), pp. 373-374.
- IEEE, (2018). IEEE Standard for Adoption of Open Fog Reference Architecture for Fog Computing," in IEEE Std 1934-2018 , vol., no., pp.1-176, 2 Aug 2018.
- Tang. B, Chen. Y, Hefferman. G, Pei. S, Wei. T, Yang. Qing (2016). Incorporating Intelligence in Fog Computing for Big Data Analysis in Smart Cities, in IEEE Transactions on Industrial Informatics, pp. 1-11.
- V. C. G`ung`or, D. Sahin, T. Kocak, S. Erg`ut, C. Buccella, C. Cecati, and G. P. Hancke, (2011) Smart grid technologies: communication technologies and standards, IEEE transactions on Industrial informatics, vol. 7, no. 4, pp. 529–539.
- W. Su, H. Eichi, W. Zeng, and M.-Y. Chow, (2012) “A survey on the electrification of transportation in a smart grid environment,” IEEE Transactions on Industrial Informatics, vol. 8, no. 1, pp. 1–10.
- H. Chourabi, T. Nam, S. Walker, J. R. Gil-Garcia, S. Mellouli, K. Nahon, T.A.Pardo, and H.J.Scholl, (2012) “Understanding smart cities: Anintegrative framework,” in International Conference on System Science (HICSS), pp. 2289–2297.